

JKS[®]

Installation Instructions

Product: SuperNerfs™

Part Number: PN OGS800

Application: Jeep® Cherokee XJ, 1984-01

Welcome

CONGRATULATIONS on purchasing a set of new SuperNerfs™ from JKS Manufacturing. We are committed to providing you with the best products available and your satisfaction is our first priority.

PLEASE READ these Installation Instructions carefully, and save them for future reference, as they contain important installation and maintenance information.

Important

INTENDED FOR VEHICLES WITHOUT PRE-EXISTING DAMAGE to the rocker panels or pinch welds. If damage already exists in these areas, SuperNerfs may still be installed as long as damage is not too severe and pinch welds have been properly straightened, or repaired if necessary.

SUPERNERFS SHOULD BE WELDED according to the installation instructions as this will produce the strongest, most reliable installation. However, a bolt-on installation is possible for light to medium duty use.

Tools Required

- Metric/Standard Socket Wrench Set
- Torque Wrench *
- Tape Measure
- Jack Stands
- Bottle Jack (or similar hydraulic floor jack)
- Reciprocating Saw or Die Grinder with Cut-Off Wheel (for cutting pinch weld)
- Hammer or Small Sledge *
- Drill
- 5/16" Drill Bit
- 3/16" Drill Bit
- 3/8" Drill Bit *
- 1/2" Drill Bit *
- Round or Rat-Tail File
- Thread Lubricating Oil
- Welder *
- Satin Black Spray Paint
- Factory Service Manual (recommended)

* Asterisk denotes tools that are not required for some applications. Thoroughly read instructions first to determine which tools will be required for your application.

Parts



DESCRIPTION	QTY
SuperNerfs	2
Chassis Mounting Arms	4
3/8" x 2-1/4" Bolts	8
3/8" Nylock Nuts	8
3/8" x 1" Self-Tapping Bolts	16
5/16" x 1" Bolts	10
5/16" Lock Washers	10
5/16" Flat Washers	10
Drilling Guide, 5-Hole (not pictured)	1

Installation

1. DETERMINE MOUNTING POSITION

- Identify Driver-side and Passenger-side SuperNerf by locating corresponding “D” or “P” stamped near the forward pre-threaded mounting hole on square tube.



- Position appropriate SuperNerf beneath rocker panel so that forward edge of square tube is 4-1/2” in front of the body seam that separates the rocker panel and the front fender. Mounting location must provide sufficient clearance between SuperNerfs and tires during suspension travel. **HINT: Use jack stands to support and position SuperNerfs during installation.**
- Once mounting position is determined, mark the location on the metal pinch weld where the front and rear support legs intersect it. Set SuperNerfs aside.

IMPORTANT: Make sure the lower front fender bolts do not interfere with square tube. If necessary, slightly bend pinch weld or grind the bolt head for clearance.

2. NOTCH PINCH WELDS

The Pinch Weld is the protruding body seam located beneath the rocker panels – created where adjoining layers of sheet metal are pinched together and spot welded.

- Using marks from previous step as a guide, cut notches in pinch weld to accommodate the SuperNerf support legs. Make your notches approximately 2” apart and cut all the way to the top of pinch weld (or bottom of rocker panel). **HINT: A pneumatic reciprocating saw or die grinder with cut-off wheel is useful for cutting pinch welds.**



- Remove the 2” long sections of pinch weld from the vehicle by cutting flush with rocker panel, or bend inboard until completely flat. **HINT: A hammer or small sledge is useful for bending and flattening pinch welds.**



3. DRILL PINCH WELDS

- Re-position SuperNerfs beneath rocker panels and align with mounting location.
- Locate the forward pre-threaded mounting hole on square tube of SuperNerf and mark its position on the inboard side of pinch weld. Transfer position to the outboard side of pinch weld for alignment with Drill Guide. Set SuperNerfs aside.

- Place supplied Drill Guide flat against outboard side of pinch weld and flush with bottom of rocker panel. Align mark from previous step with forward hole in Drill Guide and carefully mark all five (5) bolt hole locations on outboard side of pinch weld. **HINT: Clamping the Drill Guide to the pinch weld will prevent it from shifting as you mark hole locations.**



F = FORWARD (Toward Front of Vehicle)
↑ = UP (Toward Rocker Panel)

IMPORTANT: Position Drill Guide exactly as indicated. Forward edge will line up with front fender seam.

- Before drilling holes in pinch weld, compare with corresponding SuperNerf to ensure the locations of holes are correct. **Measure twice, drill once!**
- Drill a 3/16” pilot hole at each location, using the Drill Guide for assistance if preferred.
- Enlarge holes using a 5/16” drill bit.

4. MOUNT SUPERNERFS TO PINCH WELD

- Identify the Front and Rear Chassis Mounting Arms by locating the corresponding “F” or “R” stamped on the bottom of flange. Slip Front and Rear arms into appropriate legs of SuperNerfs.

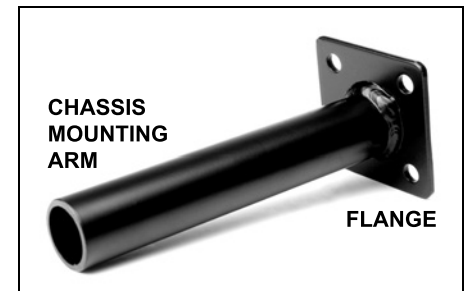

- Re-position SuperNerfs beneath rocker panels and horizontally align with mounting holes in pinch welds. It is unlikely that mounting holes will vertically align at this stage as additional force will be necessary to raise the SuperNerfs into position.
- Place a bottle jack (or similar) beneath square tube of SuperNerf. Slowly raise assembly while closely monitoring alignment of mounting holes in pinch weld. As holes align, insert a 5/16" x 1" bolt through 5/16" lock washer, 5/16" flat washer, and pinch weld before threading into SuperNerf. DO NOT tighten until all bolts have been successfully inserted. **HINT:** *If any holes in pinch weld do not align with SuperNerf, enlarge hole with a file until bolts can be inserted without difficulty. This process is easiest with SuperNerfs removed.*
- Once all bolts have been threaded into SuperNerf, carefully tighten until SuperNerf is secured to pinch weld. DO NOT over-tighten bolts. Square tube should fit closely beneath rocker panel and there should be no gap between pinch weld.

❑ 5. MOUNT SUPERNERFS TO CHASSIS

- Inspect vehicle chassis where Mounting Arm flanges will attach and remove any undercoating or debris. Flange must be flat against the mounting surface and positioned as high on the chassis as possible.
- Fully extend Mounting Arms and rotate until flanges are square with chassis. If necessary, position a bottle jack beneath Mounting Arm and raise the vertical position of flange on chassis until square tube of SuperNerf is level. **HINT:** *A right-angle drill is useful for working in close quarters. If unavailable, it is acceptable to drill holes and insert bolts at slight angle due to limited space between drill and support leg.*

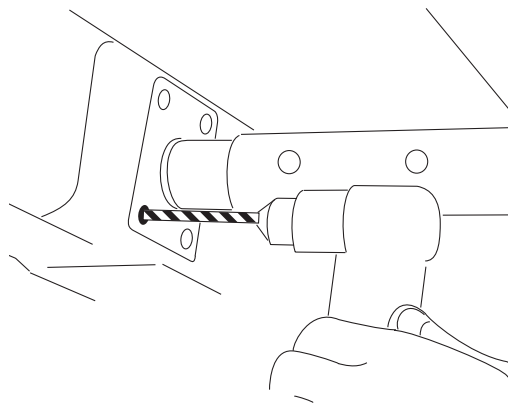

- Using the flange as a guide, drill a 5/16" hole in vehicle chassis. Insert a 3/8" x 1" self-tapping bolt into the hole and carefully tighten until bolt is snug. Repeat this step one at a time until all bolts have been installed.

IMPORTANT: *Use extreme care to avoid stripping threads when tightening self-tapping bolts in chassis. Lubricating oil will ease installation.*

❑ 6. SECURE CHASSIS MOUNTING ARMS TO SUPPORT LEGS

Chassis Mounting Arms may be bolted or welded to SuperNerf support legs to complete the installation. For best performance and the strongest connection, JKS highly recommends the welded installation.

HINT: *Before welding, remove any protective powdercoat finish so that bare metal is exposed.*

Weld-On Installation

- Enlarge pre-drilled holes located on SuperNerf support legs to at least 1/2" diameter. DO NOT drill through Chassis Mounting Arms.
- Rosette weld support legs to Mounting Arms at each hole.
- Finally, weld the end of SuperNerf support legs to Mounting Arms.

Bolt-On Installation

- Using the pre-drilled holes located on support legs of each SuperNerf as a guide, drill through the Chassis Mounting Arms using a 3/8" drill bit.

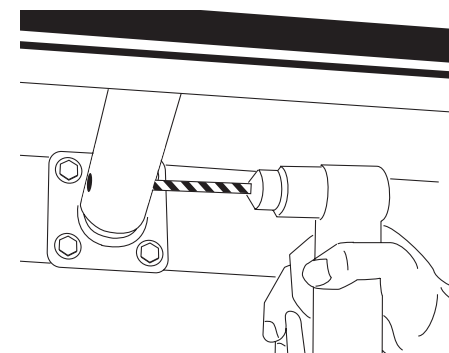

- Insert supplied 3/8" x 2-1/4" cross bolts and secure with 3/8" Nylock nuts. Tighten to 40 ft-lb. using a torque wrench.
- If possible, weld end of SuperNerf support legs to Mounting Arms for added security.

❑ 7. PROTECT ANY BARE METAL

- Carefully inspect and locate any areas where bare metal has been exposed due to cutting, grinding, drilling, or welding. Paint unprotected areas to prevent corrosion.

Maintenance

Surface of SuperNerfs may become scratched or blemished under normal operating conditions. To recondition the appearance and protect from corrosion, satin black spray paint provides a close match to the original powdercoat finish.

© 2009 JKS Manufacturing, Inc & Aftermarketing, LLC
Revision Date 8/21/2009