

JKS[®]

Installation Instructions



Product: **Rear Trackbar Relocation Bracket**

Part Number: **PN OGS170**

Application: **Jeep Wrangler JK, 2007+**

Welcome

CONGRATULATIONS on purchasing a new Rear Trackbar Relocation Bracket from JKS Manufacturing. We are committed to providing you with the best products available and your satisfaction is our first priority.

PLEASE READ these Installation Instructions carefully, and save them for future reference, as they contain important installation and maintenance information.

Important

REQUIRES 2.0-6.0" SUSPENSION LIFT.

VEHICLES LIFTED OVER 3.0" must be equipped with adjustable rear track bar [JKS PN OGS159 or equivalent] and/or adjustable upper control arms.

COMPATIBLE WITH double cardan (U-joint) CV-type or OE Rzeppa-joint driveshaft.

NOT COMPATIBLE WITH right hand drive vehicles.

CHECK TORQUE SPECIFICATIONS regularly.

Tools Required

- Hydraulic Floor Jack & Jack Stands
- Metric/Standard Socket Wrench Set
- Torque Wrench
- Tape Measure
- Factory Service Manual (recommended)

* Indicates tool that may not be necessary for every installation. Thoroughly read instructions in advance to determine which tools will be required for your application.

Parts

	DESCRIPTION	PART #	QTY
A	Relocation Bracket	PN 170000	1
B	Riser Brace	PN 170001	1
C	U-Bolt	PN 61208B	1
D	1/2" Flat Washer	PN 33086	2
E	1/2" Nylock Nut	PN 37130	2
F	3/8" x 1" Bolt	PN 13105	2
G	3/8" Flat Washer	PN 33082	4
H	3/8" Ovalok Nut	PN 37264	2
I	M14 x 80mm Bolt	PN 11113290	1
J	M14 Nylock Nut	PN 11129042	1

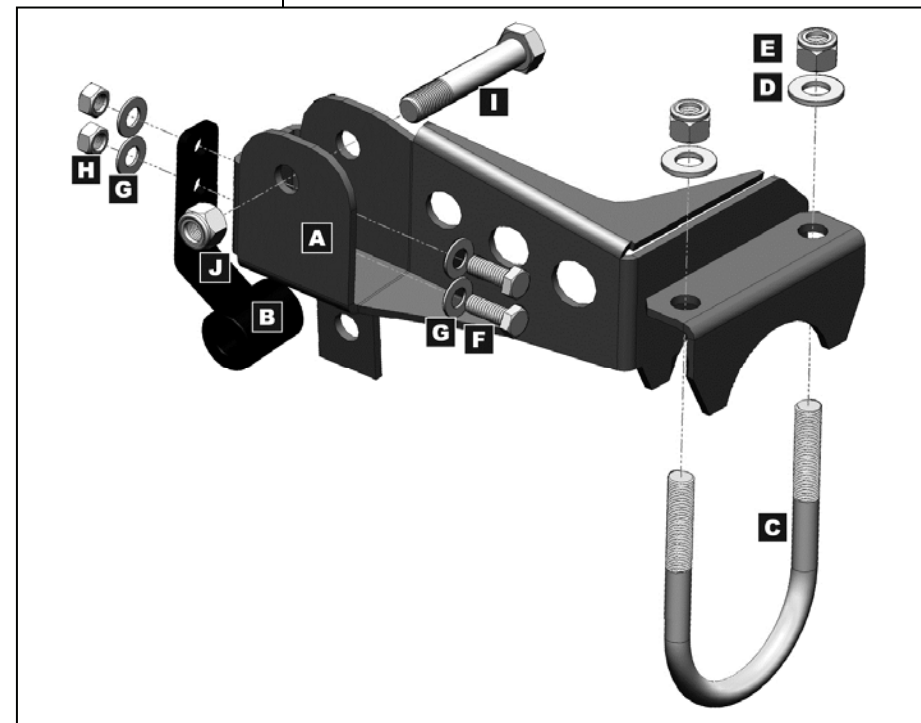

Installation

❑ 1. REMOVE REAR TRACK BAR

- Raise and support the vehicle with jack stands positioned in front of the rear lower suspension arm brackets.
- Raise and support the rear axle housing with a hydraulic jack. **HINT:** *The axle housing should be evenly supported, with the suspension at normal ride height to relieve any tension from the mounting bolts.*
- Remove the track bar mounting hardware from the axle bracket. Retain hardware.
- Loosen the track bar bolt and nut at the frame bracket but do not remove hardware.
- Remove the rear track bar from the factory axle bracket pocket and move out of way.

❑ 2. MOUNT RELOCATION BRACKET TO FACTORY AXLE BRACKET

- To ensure a proper fit, clean any dirt, debris or grease from surface of factory track bar bracket and axle tube.
- Position Relocation Bracket (A) directly above factory axle bracket. Make sure lower mounting tab on Relocation Bracket rests against forward face of factory axle bracket and radius edges rest on axle tube.

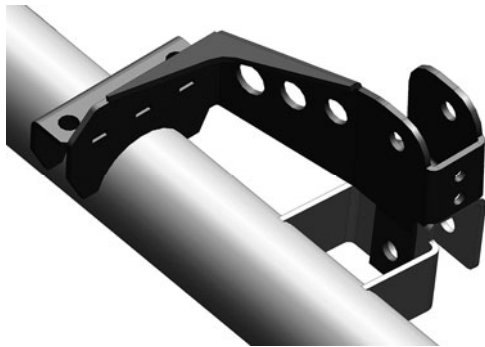

- Using the supplied U-Bolt (C), 1/2" Flat Washers (D) and 1/2" Nylock Nuts (E), loosely fasten Relocation Bracket to axle tube. **Do not tighten U-Bolt nuts yet.**

- Insert Riser Brace (B) into factory axle bracket pocket exactly as illustrated below.

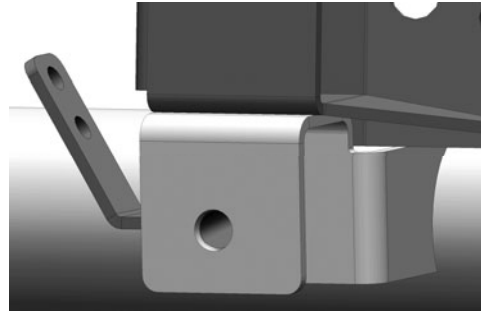

- With hole in Riser Brace (B) aligned with original track bar mounting hole, insert the original track bar mounting bolt through the factory bracket, Riser Brace and mounting tab of Relocation Bracket (A).

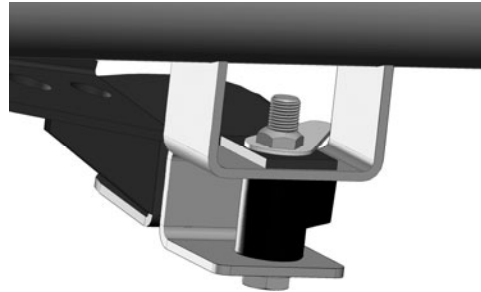

- Secure the original track bar mounting bolt with the original flag nut. **Do not tighten bolt yet.**
- Raise extension tab on Riser Brace (B) until flush against side of Relocation Bracket (A). The two mounting holes on extension tab should align with corresponding holes on side of Relocation Bracket.

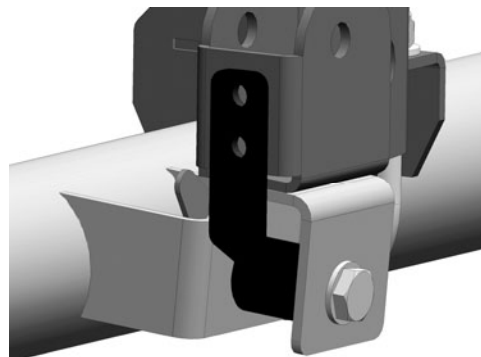

- Place a 3/8" Flat Washer (G) onto each of the supplied 3/8" x 1" Bolts (F). Insert a 3/8" Bolt with Washer into both holes on side of Relocation Bracket (A) and through mounting holes on extension tab of Riser Brace (B). **Bolts must be installed from the inside of bracket with threaded ends facing left side of vehicle.**
- Place another 3/8" Flat Washer (G) onto threads of 3/8" x 1" Bolt (F) along with a 3/8" Ovalok Nut (H). **Do not tighten bolts yet.**
- Using a torque wrench, tighten the original track bar mounting bolt to 125 ft-lbs.
- Tighten the 1/2" Nylock Nuts (E) on U-Bolt (C) to 65 ft-lbs.
- Tighten both 3/8" Ovalok Nuts (H) on Riser Brace extension tab to 40 ft-lbs.

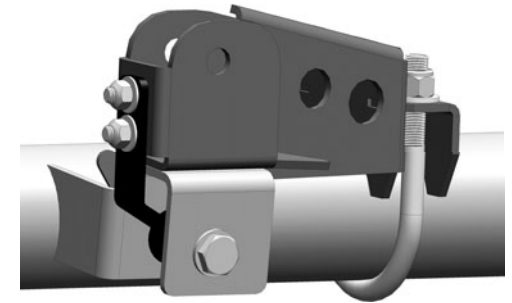

❑ 3. RE-INSTALL REAR TRACK BAR

- Slide axle end of rear track bar into pocket of Relocation Bracket (A). Make sure track bar aligns with mounting hole in bracket. **HINT:** *If track bar does not align with mounting hole, slowly raise or lower hydraulic jack supporting axle until holes align.*

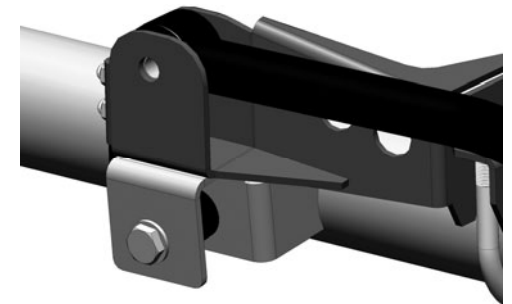

- Secure rear track bar to Relocation Bracket (A) by inserting supplied M14 x 80mm Bolt (I) through mounting hole. **Bolt must be installed from the front to the rear of the vehicle.**

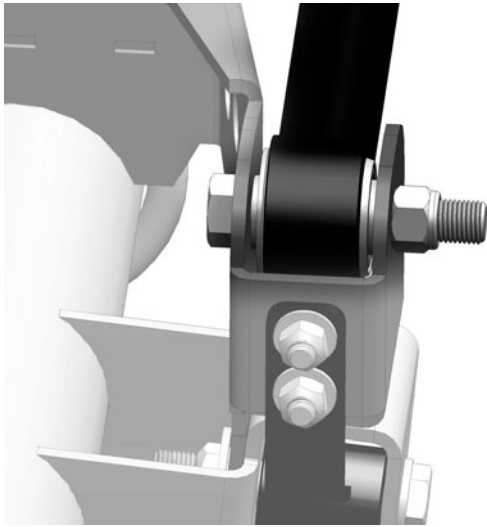

- Thread M14 Nylock Nut (J) onto M14 x 80mm Bolt (I). **Do not tighten nut yet.**
- Remove jack stands and lower vehicle to ground. **HINT: Vehicle must be at normal ride height, on level ground, with the suspension supporting the full vehicle weight.**
- Determine if the axle housing is centered by measuring the distance between the tire and chassis, using the exact same points on each side of the vehicle to ensure accuracy.



HINT: For example, measure from the edge of a tire tread lug to the outboard side of the chassis, then repeat the measurement on the other side of vehicle using exact same points.

The rear axle housing must be in perfect lateral alignment with vehicle chassis before you proceed with installation.

- Using a torque wrench, tighten track bar bolt at the frame bracket to 125 ft-lbs.
- Tighten M14 Nylock Nut (J) at axle end of track bar to 125 ft-lbs.

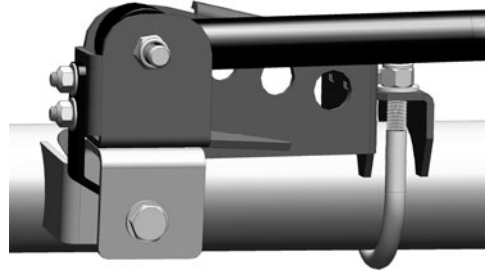

Maintenance

Check all torque specifications regularly.

© 2011 JKS Manufacturing, Inc & Aftermarketing, LLC
Revision Date 10/5/2011