

JKS[®]

Installation Instructions

Product: **Coil Spring Retainers**

Part Number: **PN 1600**

Application: **Jeep Wrangler JK, 2007+ (rear only)**

Welcome

CONGRATULATIONS on purchasing a set of new Coil Spring Retainers from JKS Manufacturing. We are committed to providing you with the best products available and your satisfaction is our first priority.

Tools Required

- Metric/Standard Socket Wrench Set
- 1/4" Allen Wrench

Parts

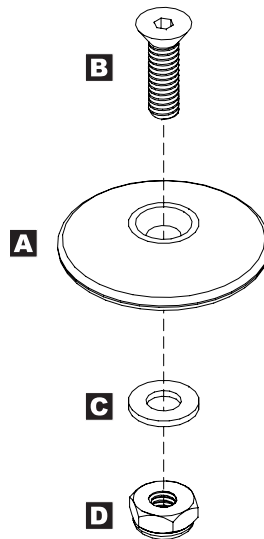

	DESCRIPTION	QTY
A	Coil Spring Retainer	2
B	7/16" x 1-1/2" Flathead Socket Screw	2
C	7/16" Flat Washer	2
D	7/16" Nylock Nut	2

Installation

- 1. INSERT COIL SPRING RETAINER**
 - Locate the 5/8" hole in the center of the lower spring mount on the rear axle.
 - Place Coil Spring Retainer (A) inside the spring by sliding it between the coils. Make sure flat side of Coil Spring Retainer faces down.
 - Position Coil Spring Retainer (A) directly on the lower spring mount as illustrated.

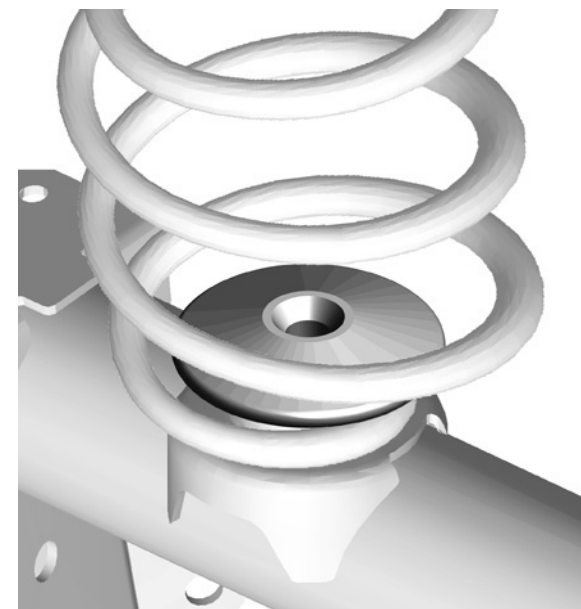

- 2. SECURE SPRING RETAINER TO LOWER SPRING MOUNT**

- Insert 7/16" x 1-1/2" Flathead Socket Screw (B) into tapered hole in center of Coil Spring Retainer (A), and through the hole in the lower spring mount.
- From beneath spring mount, slide a 7/16" Flat Washer (C) onto threads of Flathead Socket Screw (B) and install the 7/16" Nylock Nut (D).
- Secure the Coil Spring Retainer (A) to the lower spring mount by tightening the mounting hardware. Use a 1/4" Allen Wrench to prevent the 7/16" x 1-1/2" Flathead Socket Screw (B) from spinning, and tighten the 7/16" Nylock Nut (D) to 35 ft-lbs.
- Make sure the Coil Spring Retainer (A) is perfectly flat against the lower spring mount, and coil spring is secure.

© 2009 JKS Manufacturing, Inc & Aftermarketing, LLC
Revision Date 8/12/2009